



50Ω TERMINATED 18 GHz SMA N/O S.P.3 T. SWITCH

OPTIONS: /SUPP.DIODES

RF CHARACTERISTICS

NUMBER OF WAYS : 3
 FREQUENCY RANGE : 0 - 18 GHz
 IMPEDANCE : 50 Ohms

FREQUENCY (GHz)	0 - 3	3 - 8	8 -12.4	12.4- 18
V.S.W.R <=	1.20	1.30	1.40	1.50
INSERT. LOSS <=	0.20 dB	0.30 dB	0.40 dB	0.50 dB
ISOLATION >=	80 dB	70 dB	60 dB	60 dB
AVER. POWER (*)	240 W	150 W	120 W	100 W

TERMINATION IMPEDANCE : 50 Ohms
 TERMINATION AVG. POWER AT 25° C : 1 W per termination
 3 W total power

ELECTRICAL CHARACTERISTICS

ACTUATOR : NORMALLY OPEN
 NOMINAL CURRENT AT 25° C (±10%) : 250 mA
 ACTUATOR VOLTAGE (Vcc) : 12V (10.2 to 13V) / POSITIVE COMMON
 TERMINALS : solder pins (250°C max./30 sec.)

MECHANICAL CHARACTERISTICS

CONNECTORS : SMA female per MIL-C 39012
 LIFE : 2.000.000 cycles per position
 SWITCHING TIME (nominal voltage;25° C) : < 15 ms
 CONSTRUCTION : splashproof
 WEIGHT : < 250 g

ENVIRONMENTAL CHARACTERISTICS

OPERATING TEMPERATURE RANGE (°C) : -40 , +85
 STORAGE TEMPERATURE RANGE (°C) : -55 , +85

(* : average power at 25° C per RF path)

This information is given as an indication. In the continual goal to improve our products, we reserve the right to make any modifications judged necessary

4112-9212

4113-9212 This information is given as an indication. In the continual goal to improve our products, we reserve the right to make any modifications judged necessary

R574 402340

DRAWING

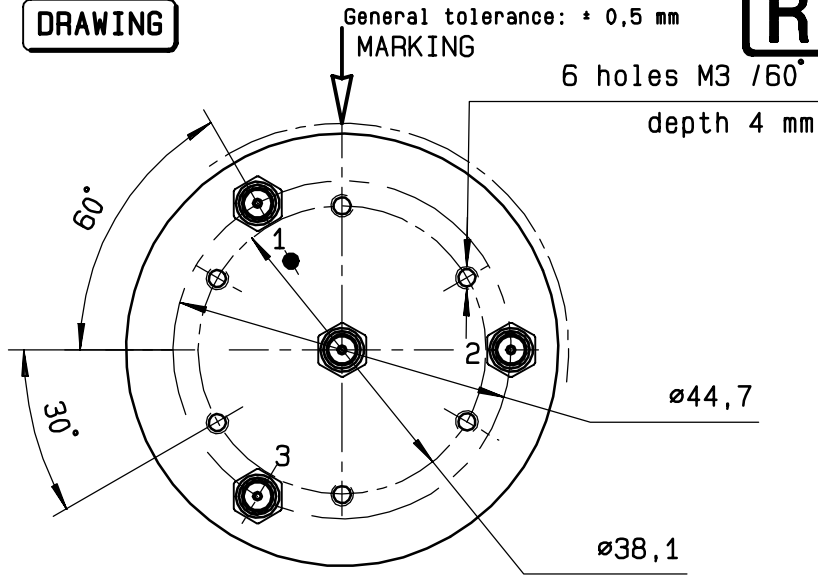

Voltage	RF continuity
+C -1	IN ↔ 1
+C -2	IN ↔ 2
+C -3	IN ↔ 3

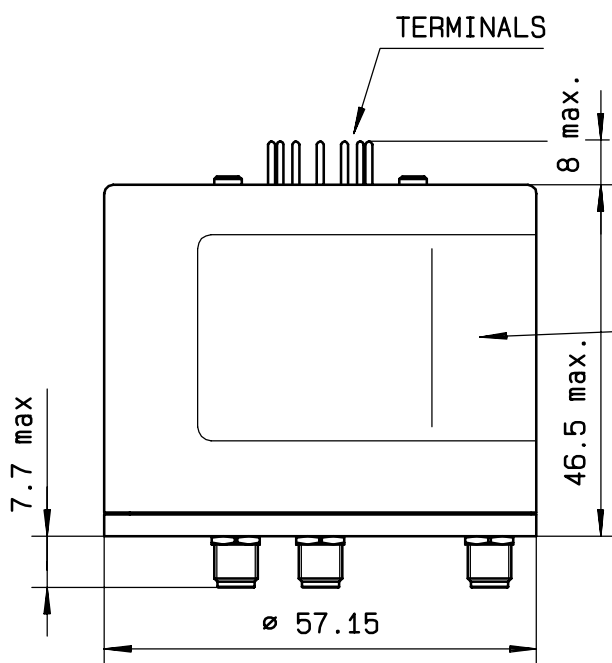

MARKING TOP VIEW (TERMINALS)

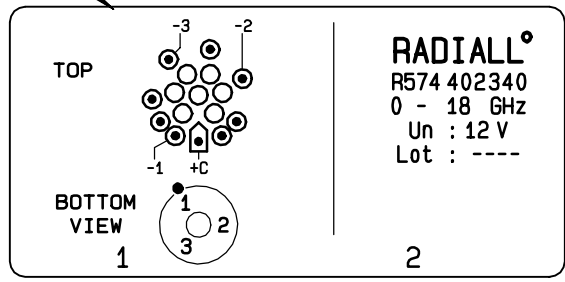

SCHEMATIC DIAGRAM

